

Catalog No. 894-1~894-3
897-1~897-3

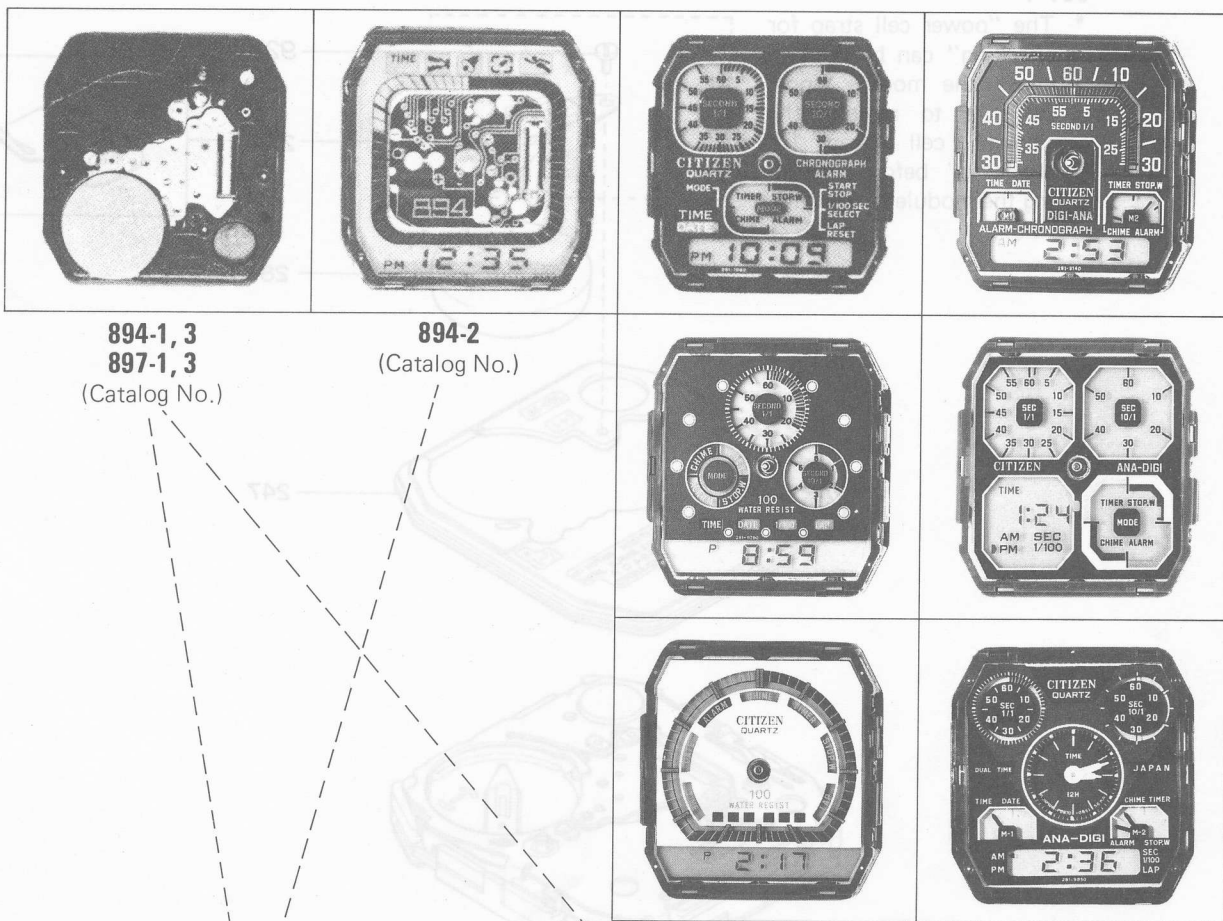

894-1, 3
897-1, 3
(Catalog No.)

894-2
(Catalog No.)

894-2
897-2
(Catalog No.)

8940A, 8940C

- Quartz crystal oscillator type LC digital display and analog display [Digital display side]
- Hour, minute and second
- Date and day
- Alarm
- Chime
- Timer
- Stopwatch
- Alarm monitor
- Power cell life indicator
- 12-24 hour switching function [Analog display side]
- Without center second (20-second step movement)

Thickness: 4.55mm

8943, 8944, 8946, 8947, 8948, 8970

- Quartz crystal oscillator type LC digital display and analog display [Digital display side]
- Hour, minute and second
- Date and day
- Alarm
- Chime
- Timer
- Stopwatch
- Alarm monitor
- Power cell life indicator
- 12-24 hour switching function [Analog display side]
- Without center second (20-second step movement)

Thickness (8943, 44, 47): 5.05mm
(8946, 48): 5.2mm
(8970): 4.5mm

Size	26mm x 27.4mm
Vibrations per second	32,768Hz

Catalog No. 894-1
897-1

* The "power cell strap for checking" can be used to check the module alone. Be sure to remove the "power cell strap for checking" before mounting the module to the case.

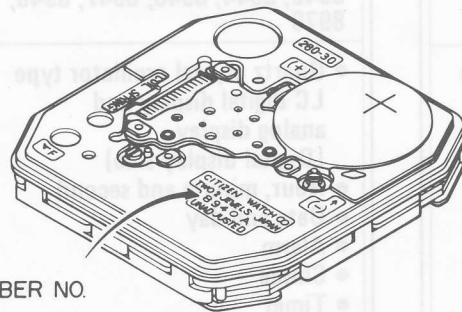
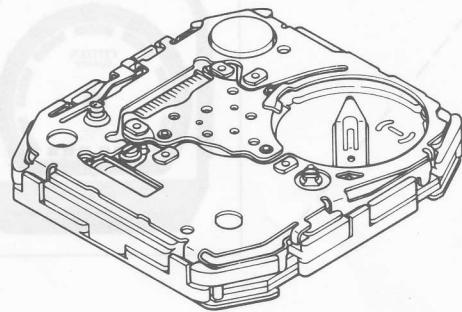
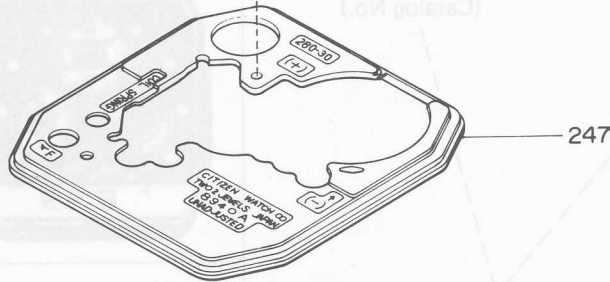
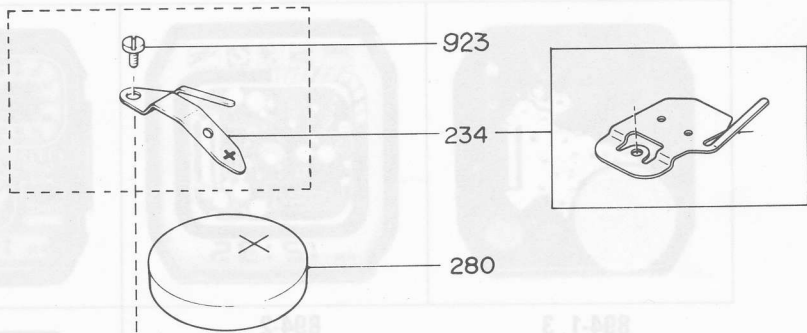

CALIBER NO.

Parts No.	Name of Parts	Caliber No.									
		8940A	8940C	8943	8944	8946	8947	8948	8970		
		Nos. of jewels									
247	Device cover	02	02	02	02	02	02	02	02		
280	Power cell	30	○	○	○	○	○	○	○		
234	Power cell strap for checking	75	○	○	○		75				
234	Power cell strap					312		312	○		
923	Screw for power cell strap for checking	69	○	○	○		69				
923	Screw for power cell strap					78		78	○		

* In the case of CAL. No. 8970, the dial is inserted between the reflecting plate and the electronic circuit unit.

Catalog No.894-2
897-2

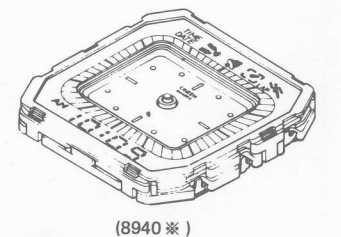
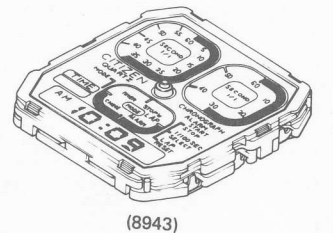
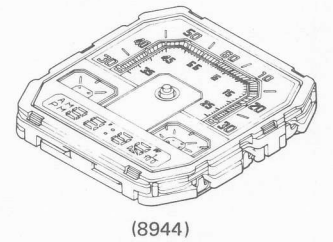
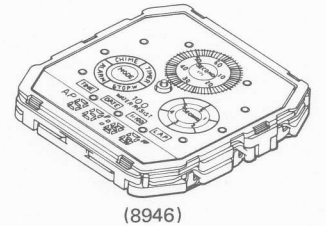
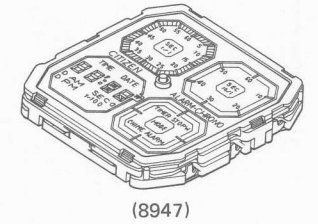
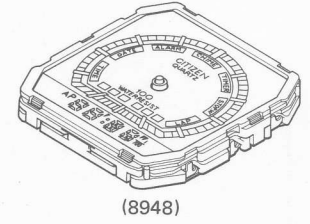
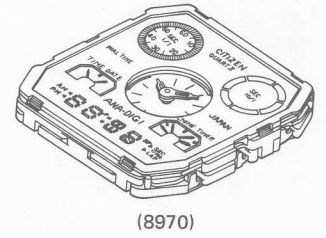
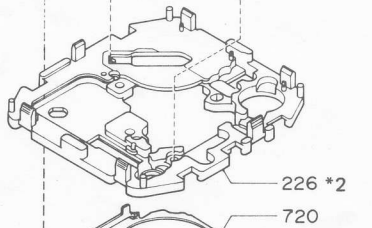
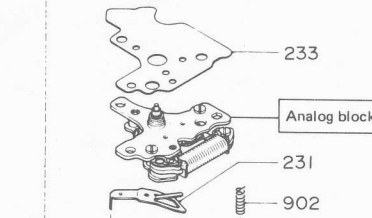
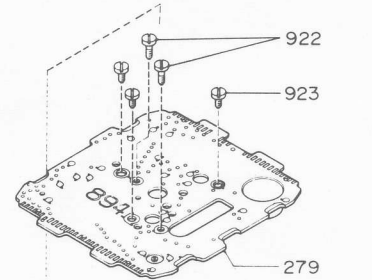
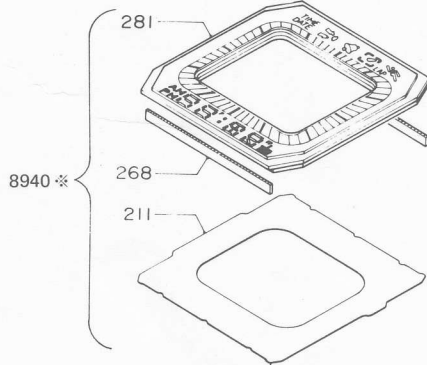
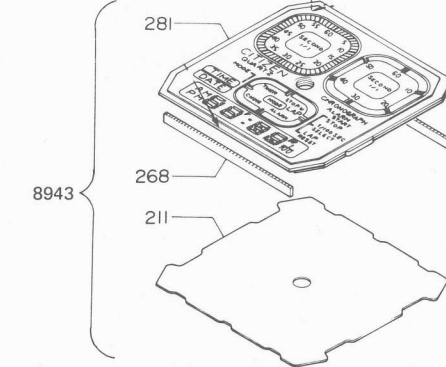
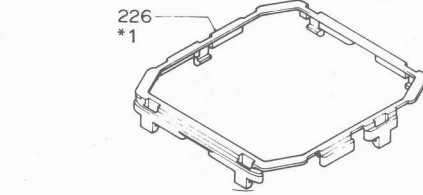
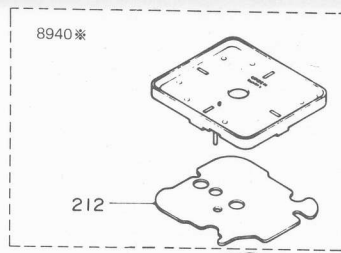
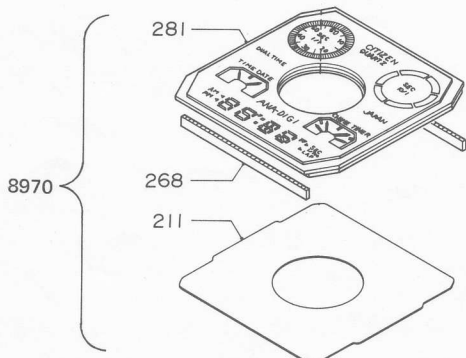
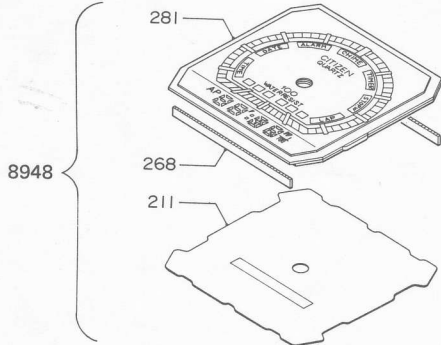
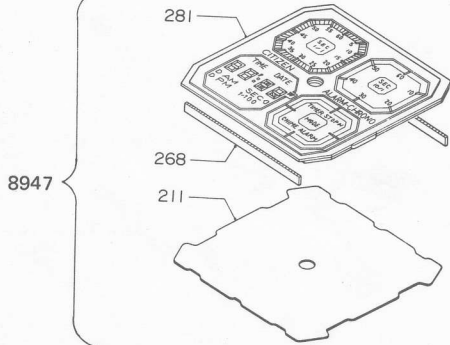
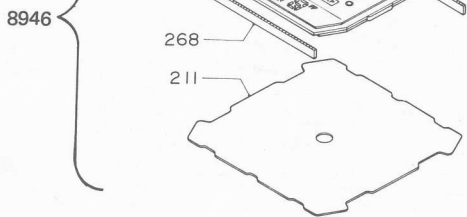
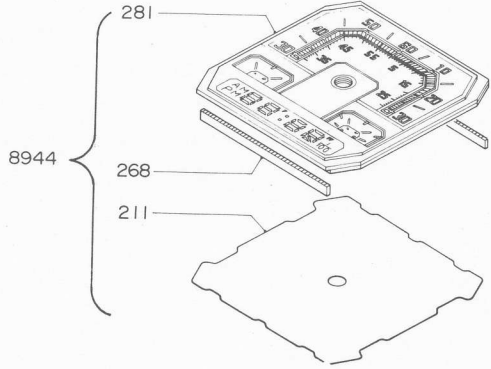

Catalog No. 894-2
897-2

Parts No.	Caliber No.		8940A	8940C	8943	8944	8946	8947	8948	8970		
	Name of parts	Nos. of jewels	02	02	02	02	02	02	02	02		
211	Reflecting plate		90	○	102	○	○	○	353	356		
211	Reflecting plate				118	○		118		357		
212	Spacer for dial		82	○								
226	LC display panel supportar *1		112	○	143	○	218	143	218	279		
226	Supporter for plate complete [I] *2		113	○	162	○	○	○	○	236		
231	Power cell connector spring		51	○	○	○	○	○	○	○		
233	Insulator sheet		136	○	○	○	○	○	○	○		
268	LC display connection rubber		60	○	72	92	○	○	○	137		
279	Unit of electronic circuit		241	○	332	○	○	○	○	492		
281	LC display panel		363	387	706	914	928	955	979	985		
281	LC display panel				708	916	931	957	982	987		
720	Supporter for plate complete [II]		039	○	○	○	○	○	○	○		
902	Buzzer contact spring		161	○	○	○	192	161	192	○		
922	Screw for coil connector		102	○	○	○	○	○	○	○		
922	Screw for plate complete		○	○	○	○	○	○	○	○		
923	Screw for unit of electronic circuit		69	○	○	○	○	○	○	○		
* 211-102	Silver											
211-118	Gold											
211-353	Silver											
211-356	Silver											
211-357	Gold											
281-706	Black											
281-708	Brown											
281-914	Black											
281-916	Brown											
281-928	Black											
281-931	White											
281-955	Black											
281-957	Brown											
281-979	Black											
281-982	White											
281-985	Gray											
281-987	Brown											

The parts No. is printed on the LC display panel and in the 6-O'clock direction.

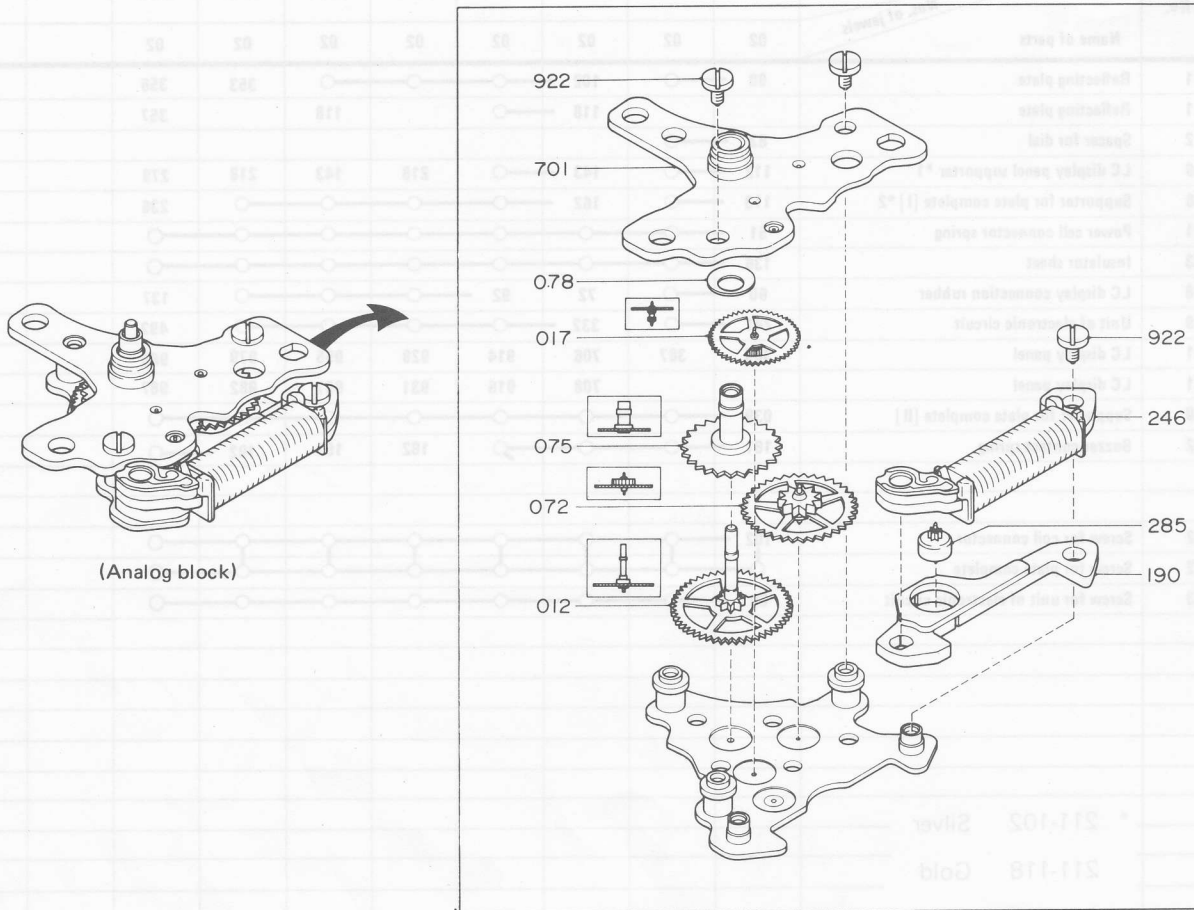

Parts No.	Name of parts	Caliber No.								
		8940A	8940C	8943	8944	8946	8947	8948	8970	
		Nos. of jewels								
		02	02	02	02	02	02	02	02	
701	Train wheel bridge	462	○	○	○	○	○	○	○	
012	Center wheel and pinion	138	○	144	○	○	○	○	138	
017	Third wheel and pinion	98	○	○	○	○	○	○	○	
072	Minute wheel and pinion	72	○	○	○	○	○	○	○	
075	Hour wheel	173	○	189	○	○	○	○	173	
078	Dial washer	16	○	○	○	○	○	○	○	
190	Stator	29	○	○	○	○	○	○	○	
246	Coil unit	42	○	○	○	○	○	○	○	
285	Rotor	27	○	○	○	○	○	○	○	
922	Screw for train wheel bridge	132	○	○	○	○	○	○	○	
922	Screw for coil unit		○	○	○	○	○	○	○	

Jewels

Parts No.	Name of parts	Caliber No.								
		8940A	8940C	8943	8944	8946	8947	8948	8970	
		Nos. of jewels								
		02	02	02	02	02	02	02	02	
942	Rotor /U	18	○	○	○	○	○	○	○	
942	Rotor /L		○	○	○	○	○	○	○	